

1 PLENUM DAMPER ASSEMBLY

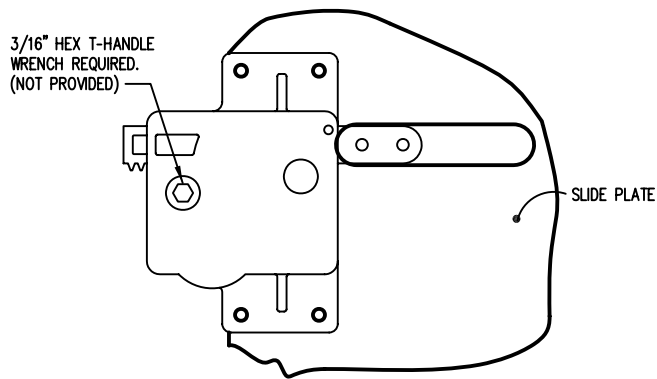

2 DAMPER ADJUSTMENT ASSEMBLY

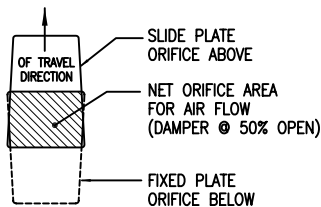

3 ORIFICE DETAIL

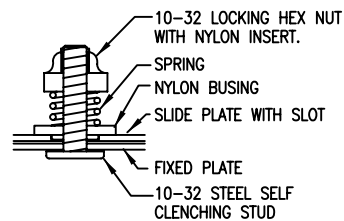

4 CLAMP STUD DETAIL

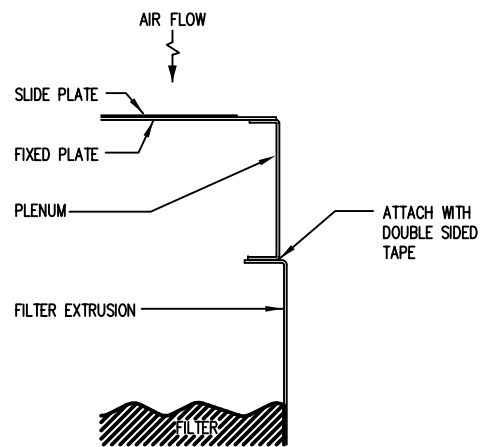

5 ENLARGED DETAIL

MATERIALS OPTIONS:

- STAINLESS STEEL
- ALUMINUM
- GALVANIZED STEEL

FINISH OPTIONS:

- POWDER COAT
- CLEAR ANODIZED
- MILL

REVISIONS	
NO.	DATE



PLENUM DAMPER
 MODEL No. PD-5A
 U.S. PATENT #5,218,998
 NON-LOAD BEARING: STANDARD

DESIGN: WRA/BJN
 DRAWN: CRE
 SCALE: NTS
 DATE: 6/09/98
 DRAWING No.: SK-45