

1 FLAT PLATE DAMPER ASSEMBLY

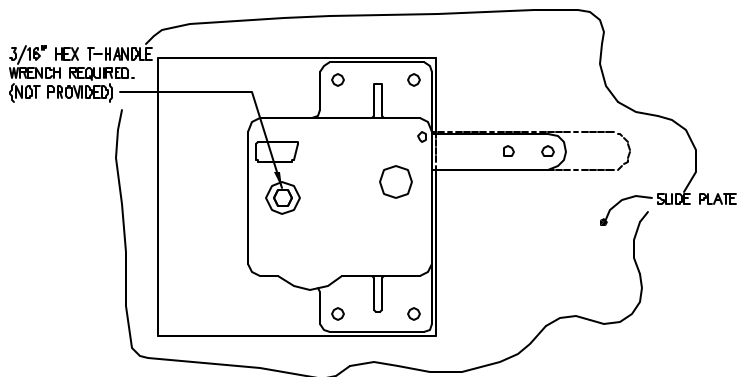

2 DAMPER ADJUSTMENT ASSEMBLY

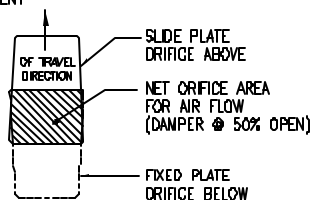

3 ORIFICE DETAIL

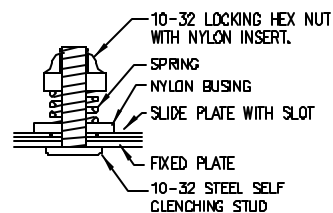

4 CLAMP STUD DETAIL

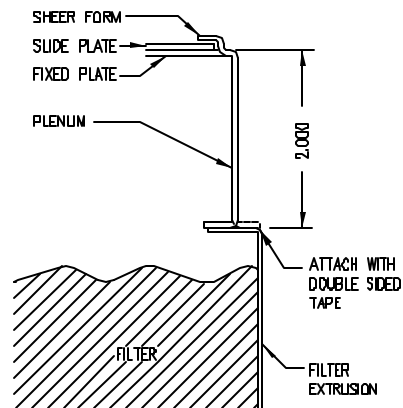

5 ENLARGED DETAIL

MATERIALS OPTIONS:

- STAINLESS STEEL
- ALUMINUM
- GALVANIZED STEEL

FINISH OPTIONS:

- POWDER COAT
- CLEAR ANODIZED
- MILL

REVISIONS	NO.	DATE	BY



**PLENUM DAMPER**  
**W/CENTER PLASTIC ADJUSTMENT**  
**MODEL No. PD-7A**  
**U.S. PATENT #5,218,998**

**DESIGN:** WRA/BJN  
**DRAWN:** CRE  
**SCALE:** NTS  
**DATE:** 5/18/99  
**DRAWING No.:** SK-66